

# SD Automatic Blast Gate

## Ordering Information

- When ordering, specify gauge (if non-standard), dimension, end styles and control circuit voltage. Material is Galvanized Steel.
- Operated by single acting compressed air magnetic cylinders, controlled by electrically connected solenoid.
- APPLICATION: Gates are used for industrial dust extraction where continuous extraction is not always needed and where manual control needs to be eliminated.

- Standard 120V control circuit and 75psi minimum air pressure. Optional 24V DC or AC control circuit available.
- All auto blast gates have cylinders with galvanized or SS body and steel rod. Single cylinder: 3" to 10". Double cylinder 12" to 24". Solenoid has plastic housing.



Ø in.	A in.	B in.	C in.	D in.	E in.	Std Weight Lbs
3	8.11	4.25	5.25	6.30	8.50	9.83
4	10.31	5.30	5.50	7.81	8.50	9.90
5	12.80	6.00	5.75	9.88	9.50	11.90
6	14.47	7.12	5.75	11.28	11.50	15.15
7	16.25	8.00	5.38	12.44	11.50	18.85
8	18.75	9.30	5.50	14.38	13.50	27.50
9	20.63	10.63	5.50	15.88	13.50	37.50
10	22.63	11.65	5.50	17.25	13.50	37.50
12	30.00	16.00	5.25	23.25	n/a	44.00
14	33.04	18.38	5.25	25.29	n/a	50.00
16	38.52	20.38	11.25	29.65	n/a	63.00
18	46.69	22.38	11.25	37.04	n/a	74.00
20	48.69	24.38	11.25	38.04	n/a	83.00
22	50.69	26.38	11.25	39.04	n/a	104.00
24	55.50	31.28	11.25	42.40	n/a	125.00

## QF Material Options

Galv			
Gauges	Size (inches)		Not available in SS
	Min. Ø	Max. Ø	
Standard	22	3	12
	20	14	24
Optional	18 (Collar)	3	24
	16 (Collar)	8	24

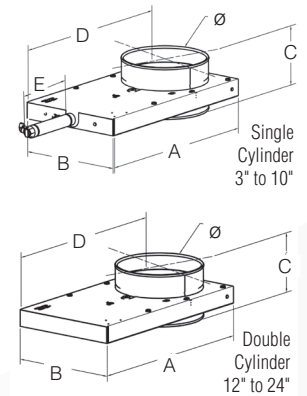

## Flanged Material Options

Galv			
Gauges	Size (inches)		Not available in SS
	Min. Ø	Max. Ø	
Standard	22	3	12
	20	14	24
Optional	18 (Collar)	3	24
	16 (Collar)	8	24

### Optional End Styles

Standard QF end can be changed to Raw ID (RI), Raw OD (RO), No Fitting (NF), Flat Flange (FFL), Angle Flange (AFL), or Van Stone (VS).

**Temperature Rating:** Max. temperature limited to 120°F unless solenoids are located outside of housing. Max temperature for the Poly tubing on the outside of the housing and Seal (UHMW) is 150°F.

Additional Product Components and Notes				
Poly tube	0.25" OD x 0.04 wall poly tube, 120 PSI, Grade E5 LIP, Type 1			
Magnetic Cylinder	Gate Size	Stroke	No. of Cylinders	
	3"	1.06 x 3.00	1	
	4"	1.06 x 4.00		
	5"	1.06 x 5.00		
	6"	1.06 x 6.00		
	7"	1.06 x 7.00		
	8"	1.06 x 8.00		
	9"	1.06 x 9.00		
	10"	1.06 x 10.00		
	12"	1.06 x 12.00		2
	14"	1.06 x 14.00		
	16"	1.06 x 16.00		
	18"	1.06 x 18.00		
20"	1.06 x 20.00	2		
22"	1.06 x 22.00			
24"	1.06 x 24.00			
Crimped round body 304SS tube only. End caps aluminum (non-repairable).				
<ul style="list-style-type: none"> <li>• Ports 0.125" NPT standard</li> <li>• Piston rod diameter 0.312", material 304SS only</li> <li>• Single acting end</li> <li>• Standard fluid: filtered air</li> <li>• Operating medium: pneumatic, 250 PSI max. (normal operating pressure 80 PSI min.)</li> </ul>				
Solenoid Options	<ul style="list-style-type: none"> <li>• Single Solenoid, 2 Position, 110VAC, 2.5 watts, 1/8" NPT; IP65 Rated, RoHS, CE</li> <li>• Single Solenoid, 2 Position, 24VDC, 2.5 watts, 1/8" NPT; IP65 Rated, RoHS, CE</li> <li>• Single Solenoid, 2 Position, 24VAC, 2.5 watts, 1/8" NPT; IP65 Rated, RoHS, CE</li> </ul>			
Coil Options	<ul style="list-style-type: none"> <li>• 24VDC</li> <li>• 24VAC / 12VDC</li> <li>• 110VAC</li> </ul>			

## Reed Switch Assembly 1.06

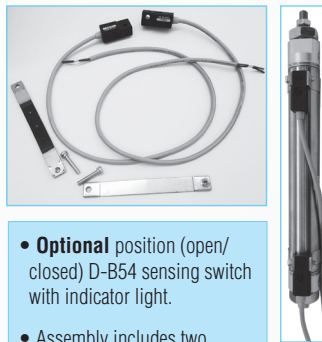

- **Optional** position (open/closed) D-B54 sensing switch with indicator light.
- Assembly includes two switches, one indicating open position and one indicating closed position.
- Applies to both styles of Nordfab Automatic Blast Gates.

