

Tabular Rivet Adapter (QF)

Ø mm	O/D mm	I/D mm	Rolled Edge (nom. mm.)	Length (nom. mm)	Weight kg	Galvanised Steel
080	79	78	6	46	0,10	0,7
100	98	97	6			
125	124	123	6			
140	139	138	6			
150	148	147	6			
160	159	158	6			
180	179	178	8			
200	200	199	8			
224	250	249	8			
250	298	297	8			
300	313	312	10			
315	348	347	10			
350	400	398	10		0,9	
400	449	447	10			
450	499	497	10			
500	559	557	10			
560	629	627	10			
630	709	707	10			
710	709	707	10			

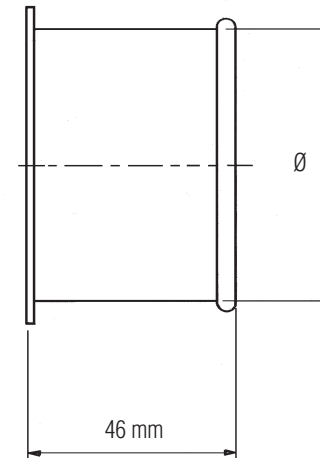

Compliance / Rating of Product Components		
Product	Material	Compliance / Rating
Tabular Rivet Adapter	Galvanised	DX51D with Z275 Coating
Joka Seal Metal Sealant 2315	Acetone blend	AAMA Specification 801.1

Temperature Rating of Product Components		
° C	Tabular Rivet Adapter	Sealants
200°	Galvanised Steel	
121°		Joka Seal Metal Sealant 2315
-20°		

Additional Notes

At temperatures ranging between 200° C and 250° C, the zinc-iron alloy layers in galvanised steel will continue to provide a high level of protection from corrosion. However, there may be some peeling, changes in mechanical properties, and reduction in the corrosion protection. Recommended max. service temperature is 200° C.