

Ø mm	Ø _A mm	Length mm	Thickness mm	
100	80	150	0,9	
125	100			
140	125			
150	140			
160	150			
180	160			
200	180			
224	200			
250	224			152
300	250			200
315	300	150		
350	315	170		
400	350	200		
450	400	200		
500	450	200		
560	500	200		
630	560	200		
710	630	220		

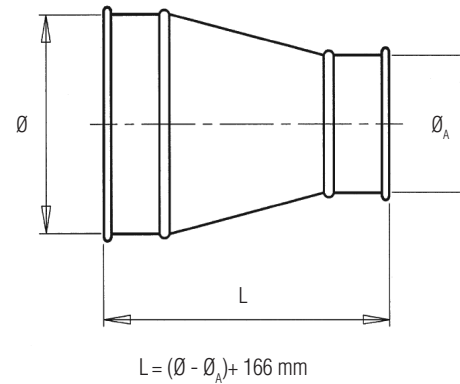

Temperature Rating of Product Components		
° C	Reducer	Sealants
200°	Galvanised Steel	
121°		Joka Seal Metal Sealant 2315
-20°		Joka Seal Metal Sealant 2315

Compliance / Rating of Product Components		
Product	Material	Compliance / Rating
Reducer	Galvanised	DX51D with Z275 Coating
Joka Seal Metal Sealant 2315	Acetone blend	AAMA Specification 801.1

Additional Notes
At temperatures ranging between 200° C and 250° C, the zinc-iron alloy layers in galvanised steel will continue to provide a high level of protection from corrosion. However, there may be some peeling, changes in mechanical properties, and reduction in the corrosion protection. Recommended max. service temperature is 200° C.

Ends

Standard QF end can be changed to Raw ID (I/D), Raw OD (O/D), Hose Adapter (FX), Flat Bar Flange (FL), or 6mm turned out edge (FB).

Construction

Seam: longitudinal seam is lapped, spot welded, and caulked.

Collars: located on the exterior side of each port and considered as air flow non-directional. Collars have lapped, spot welded and caulked longitudinal seam.

If air flow directional product is required, it must be stated on the PO and additional cost may be incurred. A raised lap seam and **spot weld are used for attaching the collar to the body and no caulking is used. If caulking is required, order QFS Reducer.**