

Radial Arm Saw Hood

Ordering Information

- When ordering, specify material and size.
- Used to collect dust from Radial Arm Saws.
- Body is 18 gauge. Collar and transition are 22 gauge as standard construction.

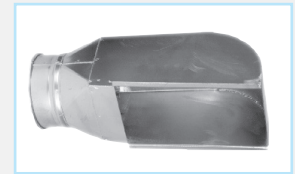

Ø in.	L in.	Std Weight Lbs
4	15.5	3.50
5	20	3.90
6	29	4.20

QF Material Options

Galv				SS			
Gauges	Size (in)		Gauges	Size (in)			
	Min. Ø	Max. Ø		Min. Ø	Max. Ø		
Standard	Collar* 22	4	6	Standard	Collar* 22	4	6
	Body is 18ga				Body is 18ga		

Flanged Material Options

Galv				SS			
Gauges	Size (in)		Gauges	Size (in)			
	Min. Ø	Max. Ø		Min. Ø	Max. Ø		
Standard	Collar* 22	4	6	Standard	Collar* 22	4	6
	Body is 18ga				Body is 18ga		

* Collar and transition. Contact Nordfab if you have need of additional collar gauge options.

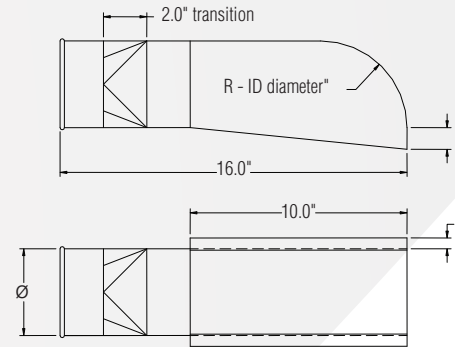

Construction:

Seam: spot welded and caulked.

Collars: have a laser welded longitudinal seam. Collars are attached to the body using a raised hemmed, spot welded seamed construction and are painted at welds.

Optional End Styles

Standard QF end can be changed to Raw ID (RI), Raw OD (RO), No Fitting (NF), Flat Flange (FFL), Angle Flange (AFL), or Van Stone (VS).